

2.5×2.0 SMD Thermistor Crystal

Part Number Guide

T-M-FF.FFFM-LC-FTFS-OT-ESR-TR-S

T (Type 型号): NH=2.5×2.0 SMD Thermistor Crystal

M (Mode of Operation 振荡模式): F=Fundamental

F (Frequency 标称频率): Normal - 5 digitals of Frequency, e.g. 16.000M

Special - All digitals of Frequency, e.g. 28.63636M

LC (Load Capacitance 负载电容): 20=20pf 00=series, etc

FT (Frequency Tolerance 调整频差): 30=±30 ppm, etc

FS (Frequency Stability 温度频差): 50=±50 ppm, etc

OT (Operating Temperature 工作温度): 1060=-10°C to +60°C 4085=-40°C to +85°C, etc

ESR (Equivalent Series Resistance 等效阻抗)

TR (Tape and Reel 编带)

S (Special Requirement 特殊要求)

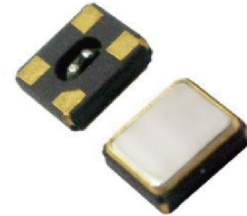

Pb Free

RoHS Compliant
 Directive 2002/95/EC

Electrical Specifications 电气参数

型号	Holder Type	2.5x2.0mm Ceramic Surface Mount
频率范围	Frequency Range	19.200MHz to 54.000MHz
调整频差	Frequency Tolerance (ΔF) (at 25°C)	±10ppm to ±100ppm
温度频差	Frequency Stability	±10ppm to ±100ppm
工作温度范围	Operating Temperature Range	-10°C ~ +60°C to -40°C ~ +85°C
储存温度范围	Storage Temperature Range	-40°C ~ +85°C / -55°C ~ +125°C
老化	Aging (25°C)	±5ppm/year Maximum
静电容	Shunt Capacitance (C0)	7pF Maximum
激励功率	Drive Level	10μW Typical
绝缘阻抗	Insulation Resistance (Rs)	500 Megaohms Minimum at D.C.100V
负载电容	Load Capacitance (CL)	Suggested by customer
热敏阻值	Thermistor Resistance (25°C)	100KΩ
热敏电阻介电常数	Thermistor B-Constant (25-50°C)	4250k

Mechanical Dimensions 外型尺寸

UNIT (单位): mm (毫米)

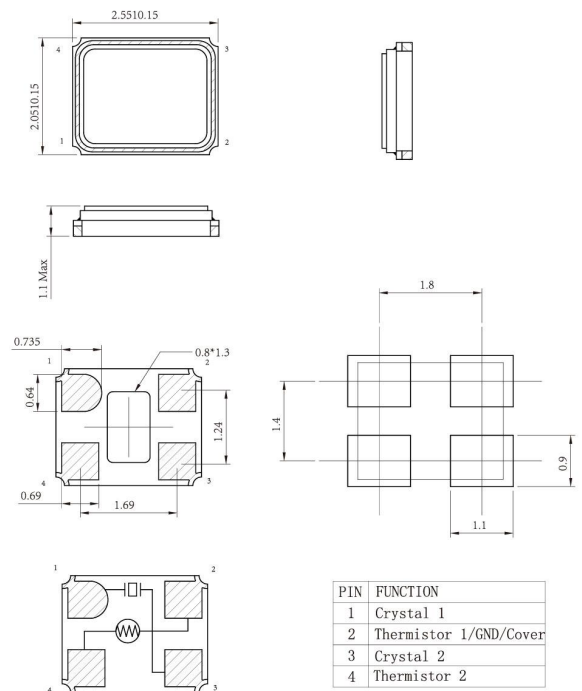

Equivalent Series Resistance and Mode of Operation 等效阻抗和振荡模式

Frequency Range 频率范围	ESR (Ω) 等效阻抗	Mode 振荡模式
19.200-30.000MHz	80Max	Fundamental
30.000-54.000MHz	50Max	Fundamental

Reflow Condition 回流焊条件

