

# 5×7 SMD VCTCXO

Part Number Guide			
<b>TXT10 - XXXXX - FREQ.</b>			
TXT10: Package-5×7 SMD VCTCXO			
XXXXX: Input Voltage/Temp. Range/ Temp. Stability/Output/Adjustment Range			
FREQ.: Frequency in MHz			
Example: TXT10-AASCN-10MHz (3.3V, ±0.3ppm@ -40°C~85°C, CMOS, no adjustment)			
Parameters 参数		Coding Table 代码表	
11	Frequency Range 频率范围	5MHz-52MHz	
~		For CMOS Output	5,6,4,8,192,10,12,8,16,16,384,19,2,19,44,20,25MHz
		For C_Sine Output	8,192,10,12,8,16,19,2,19,44,20,24,25,26MHz
6	Input Voltage 输入电压	F: 3.0V, A: 3.3V, B:5V	
7	Temp. Range 温度范围	A: -40°C to 85°C, B: -30°C to 75°C, C: -20°C to 70°C, D: 0°C to 70°C	
8	Temp. Stability 温度稳定性	P: ±0.05ppm, Q: ±0.1ppm, R: ±0.2ppm, S: ±0.3ppm, T: ±0.5ppm, U: ±1.0ppm	
9	Output Waveform 输出波形	C: CMOS, S: Clipped Sine Wave	
10	Adjustment Range 调频范围	H: ±5ppm ~ ±10ppm N: No Adjustment	
Voltage 电压			
Input Voltage 输入电压	3.0V ±5%	3.3V ±5%	5V ±5%
VCO Center Voltage 压控端中心电压	1.5V	1.65V	2.5V
VCO Input Range 压控端电压范围	0~3V	0~3.3V	0~5V
Typical Specification of 10MHz TCXO 典型规格			
Frequency tolerance 频率精度	< ±1ppm, after IR reflow		
Aging 老化率	< ±0.3ppm/year		
Voltage Stability 电压稳定性	< ±0.1ppm@VDC ±5%		
Load Stability 负载稳定性	< ±0.1ppm@CLoad ±5%		
Start Time 开机时间	< 2 ms		
Supply Current 消耗电流	CMOS Output	< 4 mA	
	Clipped Sine Wave Output	< 2 mA	
Output Level (CMOS) 输出电平	Output High Level	> 90% Vcc	
	Output Low Level	< 10% Vcc	
	Duty Cycle	45% ~ 55%	
Output Level (C_Sine) 输出幅度	> 0.8V Vp-p		
Load 负载	CMOS Output	15pF	
	Clipped Sine Wave Output	10KΩ//10pF	
Phase Noise 相位噪声	@100Hz	-130 dBc/Hz TYP.	
	@1k Hz	-148 dBc/Hz TYP.	
	@10k Hz	-154 dBc/Hz TYP.	
Storage Temp. Range 存储温度范围	-55~125°C		

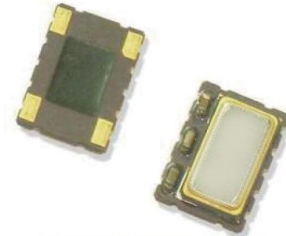

Pb Free

RoHS Compliant  
Directive 2002/95/EC

## Mechanical Dimensions 外形尺寸

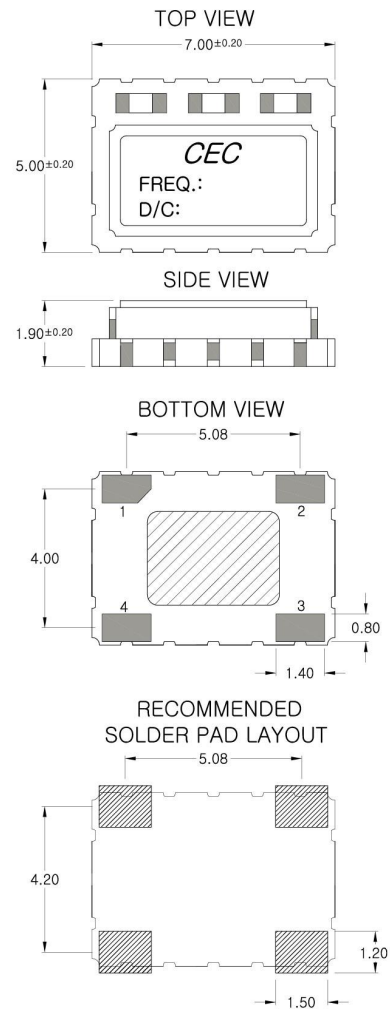

PIN No.	FUNCTION
1	Vcon:VCTCXO/ GND:TCXO
2	GND
3	R.F. Output
4	+VDC

## Reflow Condition 回流焊条件

